

CUSCADEN RESERVE

Developer Cuscaden Homes Pte Ltd

Address 8 Cuscaden Road Singapore 249732

District 10

Tenure 99 years

Estimated TOP 2nd Quarter 2022

Land size 61,596 sqft

Total units 192

Carpark 154 lots over 2 basements

Location The subject site is located in prime district 10 and across the road from the Regent Hotel. The upcoming Orchard Boulevard MRT is just minutes away.

Description 28-storey block with basement carpark, Swimming Pool and Communal Facilities.

Unit Types	1-Brm + Study	Type A1	700 sqft	24 units
	2-Brm	Type B1	807 sqft	24 units
	2-brm + Pte Lift	Type C1	818 sqft	24 units
	2-brm + Pte Lift	Type C2	807 sqft	24 units
	2-brm + Study + Pte Lift	Type D1/D2/D3	926 sqft	72 units
	3-brm + Study + Pte Lift	Type E1	1152 sqft	24 units

CUSCADEN RESERVE



Site Map - Facilities

- ① Arrival Plaza
- ② Reception Lounge
- ③ Concierge Office
- ④ Clubhouse with Lounge, Gymnasium & Changing Room
- ⑤ Yoga Garden
- ⑥ Event Pavilion
- ⑦ Pool Deck
- ⑧ Swimming Pool
- ⑨ Guardhouse

CUSCADEN RESERVE

Cuscaden Road

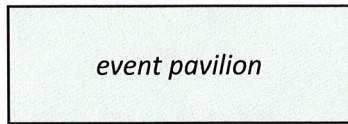
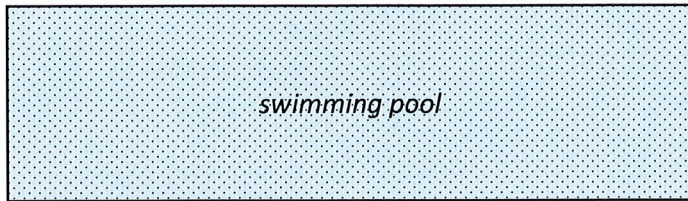

← to carpark

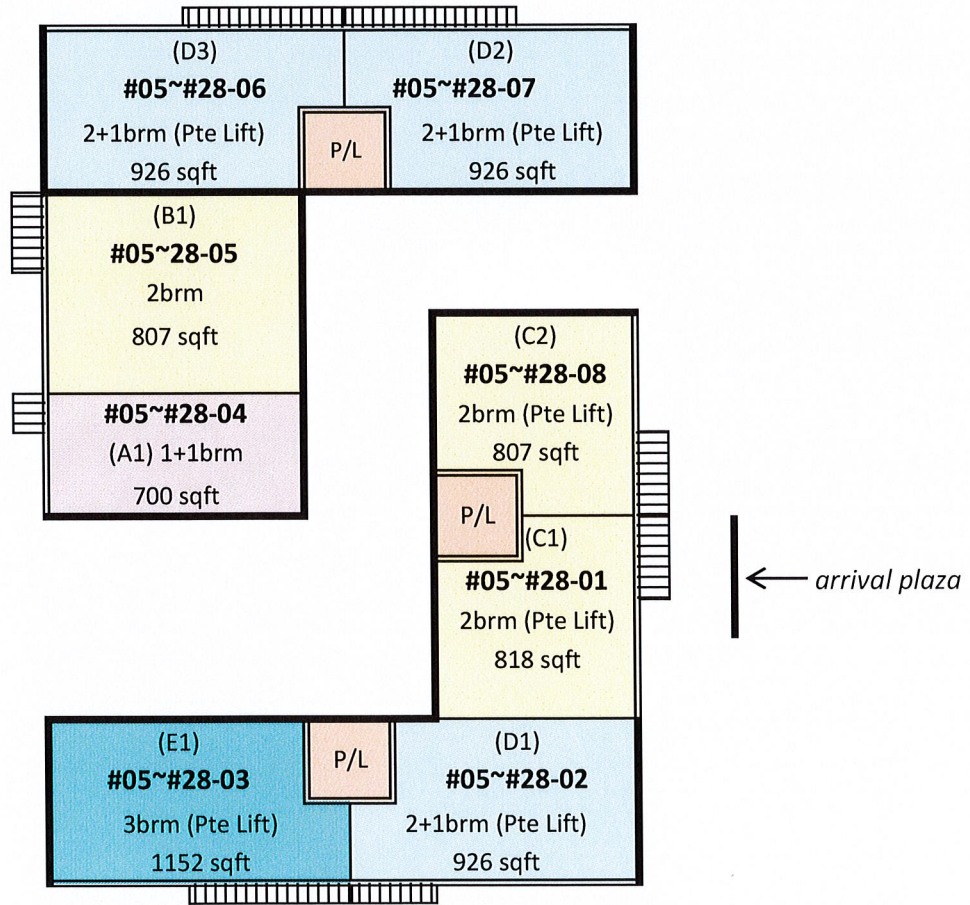

← arrival plaza



Orchard Boulevard

